

▼ Shown: S3000X



Setting New Standards in Safety, Simplicity and Performance



Two Handle Styles

Robust angled positioning handles come standard with every S-Series (X-Edition) tool. Straight positioning handles are available as accessories.

Compatible S-Series (X-Edition) wrenches	Angled positioning handles (standard)	Straight positioning handles (optional)
S1500X, S3000X	SWH6A	SWH6S
S6000X, S11000X	SWH10A	SWH10S
S25000X	Supplied with an eyebolt handle (SWH10EA)	

Safety and Performance

- Compact, high-strength uni-body construction provides a small operating radius without sacrificing endurance
- 35° rotation angle and rapid return stroke for fast operation
- Tough manifold design with added safety feature for enhanced operator safety

Simplicity

- 360° click-on reaction arm with quick release lever provides easier handling, even when wearing gloves
- Includes robust handle which mounts on both sides of tool for extra maneuverability
- Push button square drive release for quickly reversing the square drive for tightening or loosening

Versatility

- Available with optional enhanced tilt and swivel TSP300 manifold for horizontal and vertical maneuverability, with greater durability*

Accuracy

- Constant torque output provides accuracy of +/-3% across full stroke
- Optional Angle-of-Turn Indicator provides measurement of rotation

* TSP300 is designed for X-Edition tools only, and is not compatible with standard edition tools. For replacement components for existing tools, refer to repair sheet on www.enerpac.com



TSP - Pro Series Swivel

The optional TSP300 tilt and swivel manifold with robust interlocking design provides 360° X-axis rotation and 160° Y-axis rotation.

How to Order*

Factory fitted to S-Series (X-Edition) wrenches: Insert a "P" prior to the "X" in the tool designation, e.g.: **S1500PX**.

Order as an accessory using the part number: **TSP300**, which can be fitted to existing S-Series (X-Edition) wrenches.

*Includes male and female couplers.

Page: 209

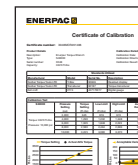

Calibration Certificate

All X-Edition tools are CE-ATEX declared, factory calibrated and are shipped complete with a calibration certificate.



S-Series, X-Edition, Square Drive Torque Wrenches

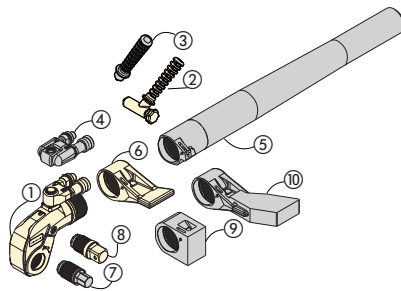

Select the Right Torque
Choose your Enerpac Torque Wrench using the untightening rule of thumb: Loosening torque equals about 250% of tightening torque.

- ① Drive Unit
- ② Angled Positioning Handle
- ③ Straight Positioning Handle (optional)
- ④ Pro Series Swivel (optional)
- ⑤ Reaction Tube Extension (optional)
- ⑥ Standard Reaction Arm
- ⑦ Allen Drive (optional)
- ⑧ Square Drive
- ⑨ Short Reaction Arm (optional)
- ⑩ Extended Reaction Arm (optional)

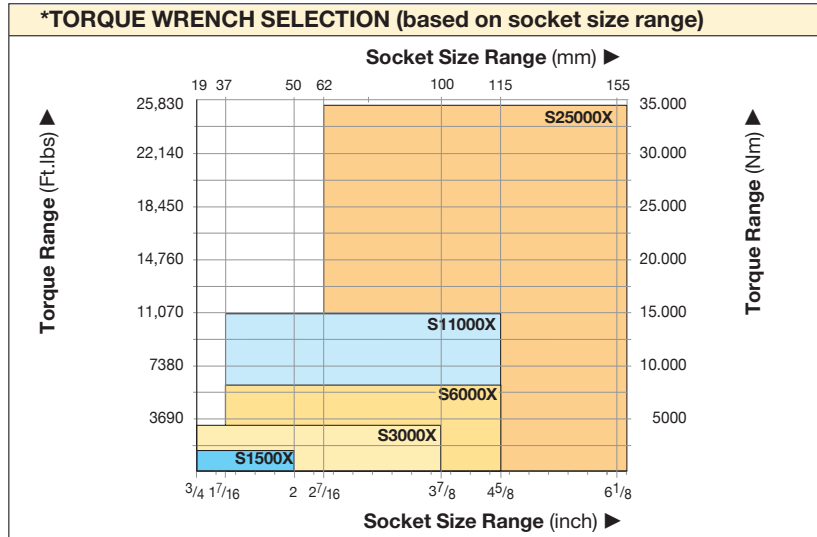

See page 210 for BSH-Sockets.

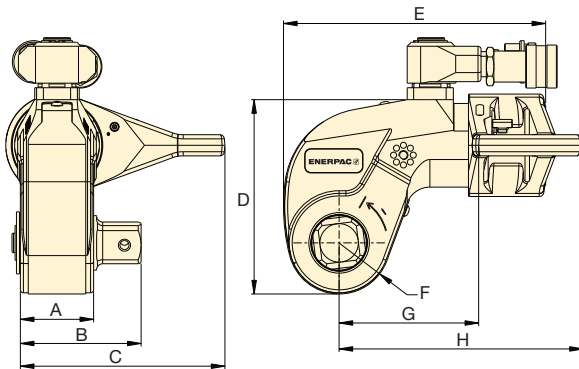

S Series (X-Edition)

Nominal Torque at 10,000 psi:
26,150 Ft.lbs

Square Drive Range:
3/4-2 1/2 inch

Nose Radius:
.98-2.52 inch

Maximum Operating Pressure:
10,000 psi



Accessory Options

A full list of optional accessories can be found on: page 209.

Page: **209**

▼ The rigid steel design of the S-Series torque wrenches provides durability, reliability and safety.



Nominal Torque at 10,000 psi / 690 bar		Minimum Torque at 10,000 psi / 690 bar		Square Drive		Angle-of-Turn Model No. (optional)	Torque Wrench Model No.*	Dimensions (in)								Wt. (lbs)
(Ft.lbs)	(Nm)	(Ft.lbs)	(Nm)	Size (in)	Model No. (included with wrench)			A	B	C	D	E	F	G	H	
1440	1952	144	195	3/4"	SD15-012	AOT15	S1500X	1.54	2.56	4.25	3.82	5.35	0.98	2.76	5.08	7.0
3225	4373	323	438	1"	SD30-100	AOT30	S3000X	1.89	3.15	5.31	5.04	6.81	1.30	3.54	6.34	12.3
6150	8338	615	834	1 1/2"	SD60-108	AOT60	S6000X	2.17	3.62	6.65	6.18	7.56	1.57	4.33	7.40	20.2
11,175	15,151	1,118	1,515	1 1/2"	SD110-108	AOT110	S11000X	2.83	4.49	7.76	7.48	8.98	1.95	5.24	9.02	34.7
26,150	35,455	2,615	3,545	2 1/2"	SD250-208	AOT250	S25000X	3.50	5.63	9.69	9.61	11.30	2.52	7.17	11.61	70.8

* To order a S-series (X-Edition) wrench fitted with the TSP swivel, insert a "P" prior to the "X" in the tool designation. e.g., **S1500PX**.

SDA-Series, Allen Drives

- ① Drive Unit
- ② Angled Positioning Handle
- ③ Straight Positioning Handle (optional)
- ④ Pro Series Swivel (optional)
- ⑤ Reaction Tube Extension (optional)
- ⑥ Standard Reaction Arm
- ⑦ Allen Drive (optional)
- ⑧ Square Drive
- ⑨ Short Reaction Arm (optional)
- ⑩ Extended Reaction Arm (optional)

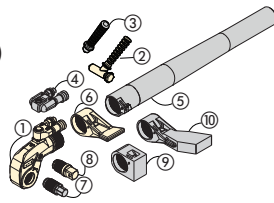

Nominal Torque at 10,000 psi:



26,150 Ft.lbs.

Hexagon Size Allen Drive:

1/2-2 1/4 in. (14-85 mm)

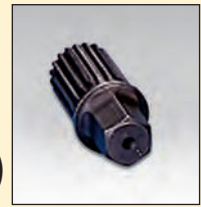
For
S
Series
(X-Edition)



TORQUE WRENCH	OPTIONAL ALLEN DRIVES, IMPERIAL				OPTIONAL ALLEN DRIVES, METRIC				SHORT REACTION ARM FOR ALLEN DRIVES		
	Model Number	Hexagon Size (in)	Maximum Torque (Ft.Lbs)	Model Number	Dim. B1 (in)	Hexagon Size (mm)	Maximum Torque (Ft.lbs)	Model Number	Dim. B1 (in)	Model Number	Dimensions (in) C1 H1
 S1500X (1440 Ft-lbs)	1/2	355	SDA15-008	2.6	14	475	SDA15-14	2.60	 SRA15X	2.66	2.56
	5/8	690	SDA15-010	2.6	17	850	SDA15-17	2.68			
	3/4	1195	SDA15-012	2.8	19	1185	SDA15-19	2.76			
	7/8	1400	SDA15-014	2.9	22	1400	SDA15-22	2.87			
	1	1400	SDA15-100	3.0	24	1400	SDA15-24	2.91			
S3000X (3225 Ft-lbs)	5/8	690	SDA30-010	3.0	17	850	SDA30-17	3.03	SRA30X	3.15	2.91
	3/4	1195	SDA30-012	3.1	19	1185	SDA30-19	3.11			
	7/8	1895	SDA30-014	3.3	22	1835	SDA30-22	3.23			
	1	2825	SDA30-100	3.4	24	2385	SDA30-24	3.31			
	1 1/8	3200	SDA30-102	3.5	27	3200	SDA30-27	3.35			
	1 1/4	3200	SDA30-104	3.5	30	3200	SDA30-30	3.43			
S6000X (6050 Ft-lbs)	5/8	690	SDA60-010	3.3	17	850	SDA60-17	3.39	SRA60X	3.60	3.50
	3/4	1195	SDA60-012	3.5	19	1185	SDA60-19	3.46			
	7/8	1895	SDA60-014	3.6	22	1835	SDA60-22	3.58			
	1	2825	SDA60-100	3.7	24	2385	SDA60-24	3.66			
	1 1/8	4025	SDA60-102	3.8	27	3395	SDA60-27	3.70			
	1 1/4	5520	SDA60-104	3.9	30	4655	SDA60-30	3.78			
S11000X (11,175 Ft-lbs)	1 1/4	5520	SDA110-104	4.5	30	4655	SDA110-30	4.41	SRA110X	5.02	4.17
	1 3/8	7345	SDA110-106	4.6	32	5650	SDA110-32	4.49			
	1 1/2	9535	SDA110-108	4.6	36	8040	SDA110-36	4.61			
	1 5/8	11,000	SDA110-110	4.8	41	11,000	SDA110-41	4.76			
	1 3/4	11,000	SDA110-112	4.9	46	11,000	SDA110-46	5.00			
S25000X (26,150 Ft-lbs)	1 1/2	9535	SDA250-108	5.5	36	8040	SDA250-36	5.51	SRA250X	6.24	5.31
	1 5/8	12,120	SDA250-110	5.7	41	11,880	SDA250-41	5.67			
	1 3/4	15,135	SDA250-112	5.8	46	16,775	SDA250-46	5.83			
	1 7/8	18,620	SDA250-114	5.9	50	21,545	SDA250-50	5.94			
	2	22,595	SDA250-200	5.9	55	26,150	SDA250-55	6.06			
	2 1/4	26,150	SDA250-204	6.0	60	26,150	SDA250-60	6.22			
	-	-	-	-	65	26,150	SDA250-65	6.34			
	-	-	-	-	70	26,150	SDA250-70	6.46			
	-	-	-	-	75	26,150	SDA250-75	6.61			
-	-	-	-	85	26,150	SDA250-85	6.89				

Accessories for S-Series, X-Edition Torque Wrenches

TSP-Series, Pro Series Swivels

- Robust interlocking design
- 360° X-axis and 160° Y-axis rotation
- Increases tool fit in restricted access areas
- Simplifies hose placement
- Includes male and female couplers

**TSP
RTEX
SRSX
Series**

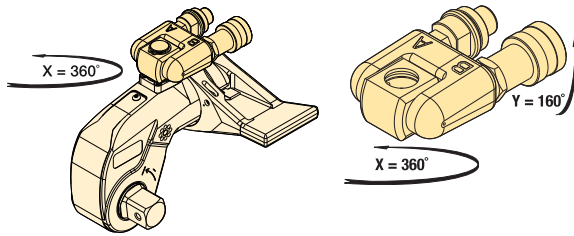

TSP Series

Torque Wrench Model Number	Model Number	Maximum Pressure (psi)	Wt. (lbs)
S1500X, S3000X, S6000X, S11000X, S25000X	TSP300*	10,000	0.44

Note: To order a S-series (X-Edition) wrench fitted with the TSP swivel, insert a "P" prior to the "X" in the tool designation, e.g., **S1500PX**.

* TSP300 is designed for X-Edition tools only, and is not compatible with standard edition tools. For replacement components for existing tools, refer to repair sheet on www.enerpac.com

RTEX-Series, Reaction Tube Extensions

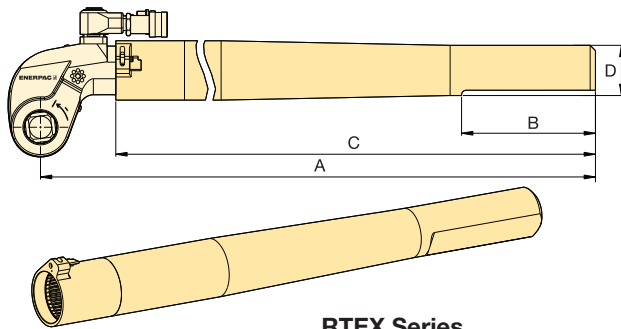

RTEX Series

- Full torque rated
- Increases tool fit in restricted access areas

Torque Wrench Model Number	Model Number	Dimensions (in)				Wt. (lbs)*
		A	B	C	D	
S1500X	RTE15X	27.80	5.98	25.04	2.28	10.1
S3000X	RTE30X	28.86	5.98	25.47	2.24	12.1
S6000X	RTE60X	29.41	5.98	25.94	2.56	17.0
S11000X	RTE110X	30.28	5.98	26.57	2.99	24.7
S25000X	RTE250X	32.01	5.98	26.97	3.94	38.1

* Weights indicated are for the accessories only and do not include the wrench.

SRSX-Series, Extended Reaction Arms

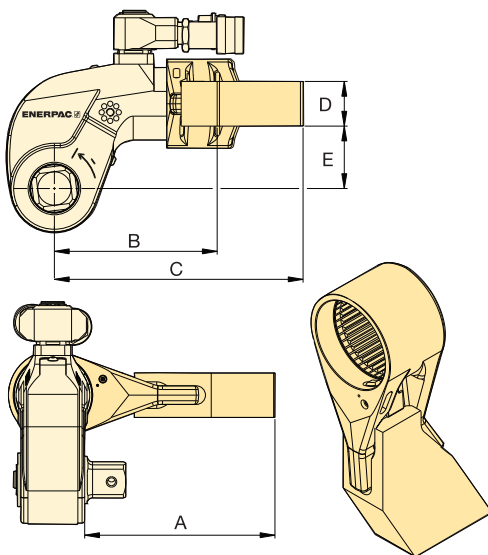

SRSX Series

- Lightweight interchangeable design

Wrench Model	Max. Torque (Ft-lbs)	Model Number	Dimensions (in)					Wt. (lbs)*
			A	B	C	D	E	
S1500X	1328	SRS151X	3.70	3.39	5.00	0.94	1.34	1.8
	1210	SRS152X	4.69	3.82	5.43	0.94	1.34	2.2
	1131	SRS153X	5.71	4.29	5.83	0.94	1.34	2.6
S3000X	2890	SRS301X	4.37	4.17	6.61	1.34	1.89	3.5
	2739	SRS302X	5.39	4.61	7.17	1.34	1.89	4.4
	2638	SRS303X	6.38	5.20	7.80	1.34	1.89	5.5
S6000X	5784	SRS601X	5.43	5.04	7.56	1.54	2.44	5.1
	5501	SRS602X	6.42	5.67	8.15	1.54	2.44	6.0
	5295	SRS603X	7.44	6.26	8.74	1.54	2.44	7.5
S11000X	10,812	SRS1101X	5.87	6.18	9.13	1.81	2.99	9.7
	10,300	SRS1102X	6.89	6.77	9.72	1.81	2.99	11.2
	9883	SRS1103X	7.87	7.36	10.28	1.81	2.99	12.8
S25000X	24,751	SRS2501X	7.20	8.23	11.61	1.97	3.94	16.8
	23,652	SRS2502X	8.19	8.74	12.20	1.97	3.94	18.5
	22,694	SRS2503X	9.17	9.29	12.83	1.97	3.94	22.0

* Weights indicated are for the accessories only and do not include the wrench.

- Heavy-duty impact sockets
- Supplied with "Pin and Ring"

Hexagon Sizes:

3/4 - 6 1/8 inch
(19 - 155 mm)



IMPERIAL SOCKETS													
3/4" Square Drive		1" Square Drive				1 1/2" Square Drive				2 1/2" Square Drive			
Model Number	A/F (in)	Model Number	A/F (in)	Model Number	A/F (in)	Model Number	A/F (in)	Model Number	A/F (in)	Model Number	A/F (in)	Model Number	A/F (in)
BSH7519	3/4"	BSH1019	3/4"	BSH10231	2 5/16"	BSH15144	1 7/16"	BSH15281	2 13/16"	BSH25244	2 7/16"	BSH25419	4 3/16"
BSH75088	7/8"	BSH10088	7/8"	BSH10238	2 3/8"	BSH1538	1 1/2"	BSH15288	2 7/8"	BSH25250	2 1/2"	BSH25425	4 1/4"
BSH75094	15/16"	BSH10094	15/16"	BSH10244	2 7/16"	BSH15156	1 9/16"	BSH1575	2 15/16"	BSH25256	2 9/16"	BSH25110	4 5/16"
BSH7527	1 1/16"	BSH1027	1 1/16"	BSH10250	2 1/2"	BSH15163	1 5/8"	BSH15300	3"	BSH25263	2 5/8"	BSH25438	4 3/8"
BSH7530	1 3/16"	BSH1030	1 3/16"	BSH1065	2 9/16"	BSH1543	1 11/16"	BSH15306	3 1/16"	BSH25269	2 11/16"	BSH25450	4 1/2"
BSH75125	1 1/4"	BSH10125	1 1/4"	BSH10263	2 5/8"	BSH15175	1 3/4"	BSH15313	3 1/8"	BSH2570	2 3/4"	BSH25463	4 5/8"
BSH75131	1 5/16"	BSH10131	1 5/16"	BSH10269	2 11/16"	BSH1546	1 13/16"	BSH15319	3 3/16"	BSH25281	2 13/16"	BSH25475	4 3/4"
BSH7535	1 3/8"	BSH1035	1 3/8"	BSH1070	2 3/4"	BSH15188	1 7/8"	BSH15325	3 1/4"	BSH25288	2 7/8"	BSH25488	4 7/8"
BSH75144	1 7/16"	BSH10144	1 7/16"	BSH10281	2 13/16"	BSH15194	1 15/16"	BSH15338	3 3/8"	BSH2575	2 15/16"	BSH25500	5"
BSH7538	1 1/2"	BSH1038	1 1/2"	BSH10288	2 7/8"	BSH15200	2"	BSH15350	3 1/2"	BSH25300	3"	BSH25513	5 1/8"
BSH75156	1 9/16"	BSH10156	1 9/16"	BSH1075	2 15/16"	BSH15206	2 1/16"	BSH15363	3 5/8"	BSH25306	3 1/16"	BSH25519	5 3/16"
BSH75163	1 5/8"	BSH10163	1 5/8"	BSH10300	3"	BSH15213	2 1/8"	BSH1595	3 3/4"	BSH25313	3 1/8"	BSH25525	5 1/4"
BSH7543	1 11/16"	BSH1043	1 11/16"	BSH10306	3 1/16"	BSH15219	2 3/16"	BSH15388	3 7/8"	BSH25319	3 3/16"	BSH25538	5 3/8"
BSH75175	1 3/4"	BSH10175	1 3/4"	BSH10313	3 1/8"	BSH15225	2 1/4"	BSH15100	3 15/16"	BSH25325	3 1/4"	BSH25140	5 1/2"
BSH7546	1 13/16"	BSH1046	1 13/16"	BSH10319	3 3/16"	BSH15231	2 5/16"	BSH15400	4"	BSH25338	3 3/8"	BSH25575	5 3/4"
BSH75188	1 7/8"	BSH10188	1 7/8"	BSH10325	3 1/4"	BSH15238	2 3/8"	BSH15105	4 1/8"	BSH25350	3 1/2"	BSH25150	5 7/8"
BSH75194	1 15/16"	BSH10194	1 15/16"	BSH10338	3 3/8"	BSH15244	2 7/16"	BSH15419	4 3/16"	BSH25363	3 5/8"	BSH25600	6"
BSH75200	2"	BSH10200	2"	BSH10350	3 1/2"	BSH15250	2 1/2"	BSH15425	4 1/4"	BSH2595	3 3/4"	BSH25613	6 1/8"
		BSH10206	2 1/16"	BSH10363	3 5/8"	BSH1565	2 9/16"	BSH15110	4 5/16"	BSH25388	3 7/8"		
		BSH10213	2 1/8"	BSH1095	3 3/4"	BSH15263	2 5/8"	BSH15438	4 3/8"	BSH25100	3 15/16"		
		BSH10219	2 3/16"	BSH10388	3 7/8"	BSH15269	2 11/16"	BSH15450	4 1/2"	BSH25400	4"		
		BSH10225	2 1/4"			BSH1570	2 3/4"	BSH15463	4 5/8"	BSH25105	4 1/8"		

METRIC SOCKETS							
3/4" Square Drive		1" Square Drive		1 1/2" Square Drive		2 1/2" Square Drive	
Model Number	A/F (mm)	Model Number	A/F (mm)	Model Number	A/F (mm)	Model Number	A/F (mm)
BSH7519	19	BSH1019	19	BSH1536	36	BSH2565	65
BSH7524	24	BSH1024	24	BSH15163	41	BSH2570	70
BSH7527	27	BSH1027	27	BSH1546	46	BSH2575	75
BSH7530	30	BSH1030	30	BSH1550	50	BSH2580	80
BSH7532	32	BSH1032	32	BSH1555	55	BSH2585	85
BSH7536	36	BSH1036	36	BSH1560	60	BSH2590	90
BSH75163	41	BSH10163	41	BSH1565	65	BSH2595	95
BSH7546	46	BSH1046	46	BSH1570	70	BSH25100	100
BSH7550	50	BSH1050	50	BSH1575	75	BSH25105	105
		BSH1055	55	BSH1580	80	BSH25110	110
		BSH1060	60	BSH1585	85	BSH25115	115
		BSH1065	65	BSH1590	90	BSH25120	120
		BSH1070	70	BSH1595	95	BSH25125	125
		BSH1075	75	BSH15100	100	BSH25135	135
		BSH1080	80	BSH15105	105	BSH25140	140
		BSH1085	85	BSH15110	110	BSH25145	145
		BSH1090	90	BSH15115	115	BSH25150	150
		BSH1095	95			BSH25155	155
		BSH10100	100				

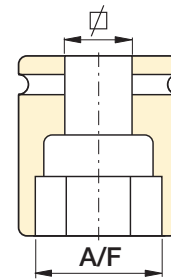

Pin and Ring

All sockets are supplied with a "Pin and Ring" to hold the socket in place on the square drive of the tool.



Select the Right Torque

Choose your Enerpac Torque Wrench using the untightening rule of thumb: Loosening torque equals about 250% of tightening torque.

ENERPAC professional series steel torque wrenches provide reliable controlled tightening solutions across many industries.

S3000X Square Drive Torque Wrench on Wind Turbine Assembly and Maintenance

S3000X used to connect wind turbine segments during assembly and maintenance. A robust but compact solution is required for bolt tightening on wind tower sections. Large numbers of fasteners require precise application of torque to ensure joint integrity is achieved and maintained.

The Enerpac S-Series wrench offers simple and reliable operation while providing accurate and repeatable results.



W4000X Low Profile Torque Wrench on an API Pipe Flange

Throughout the Oil and Gas, Petrochemical and Processing Industries, pipeline joints, valves, pumps and machinery present challenges for controlled bolting.

The restricted access on this flange was easily overcome with an Enerpac W-Series Torque Wrench. The W Wrenches offer reliability and control, ensuring even and consistent torque is applied to all bolts.

S3000X on an Oil and Gas Flange

During maintenance, quick turnaround times are essential; S-Series wrenches provide a large angle of nut rotation per stroke, offering speed and accuracy in a compact ergonomic tool.

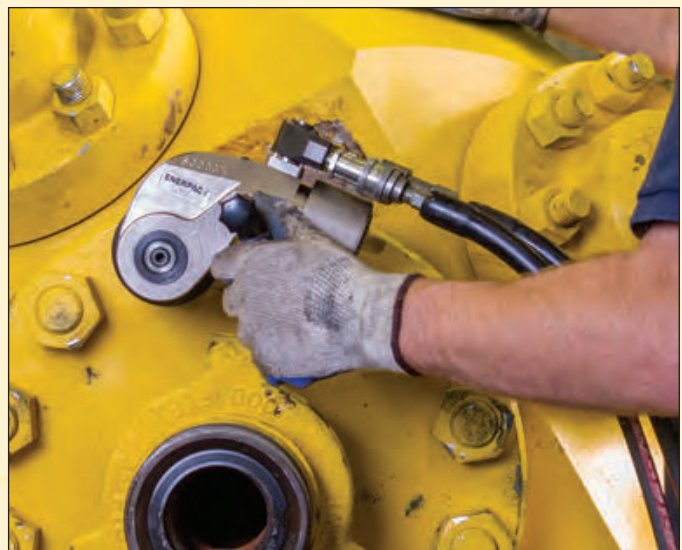

▼ Shown: W4206X cassette with W4000X drive unit
(Rear model shows optional straight handle)



Setting New Standards in Safety, Simplicity and Performance



Two Handle Styles

Robust angled positioning handles come standard with every W-Series (X-Edition) tool. Straight positioning handles designed for extreme limited access applications are available as accessories.

Compatible W-Series (X-Edition) wrenches	Angled positioning handles (standard)	Straight positioning handles (optional)
W2000X, W4000X	SWH6A	SWH6S
W8000X, W15000X	SWH10A	SWH10S
W22000X, W35000X	Supplied with an eyebolt handle (SWH10EA)	

Safety and Performance

- Superior strength to size ratio provides easy access to difficult to reach applications without sacrificing endurance
- 30° rotation angle and rapid return stroke provide fast operation
- Tough manifold design with added safety feature for enhanced operator safety

Simplicity

- Fast release drive unit enables rapid exchange of cassettes, no tools required and no pins to lose
- Includes robust handles which mount on both sides, and the tops of cassettes to allow for extra maneuverability
- Quick and easy disassembly for maintenance without special tools

Versatility

- Available with optional enhanced tilt and swivel TSP300 manifold for horizontal and vertical maneuverability, with greater durability*
- X-Edition drive units, cassettes and most accessories are compatible with standard edition tools*
- Drive unit compatible with UltraSlim and WCR-Series cassettes

Accuracy

- Constant torque output provides accuracy of +/-3% across full stroke

* TSP300 is designed for X-Edition tools only, and is not compatible with standard edition tools. For replacement components for existing tools, refer to repair sheet on www.enerpac.com



TSP - Pro Series Swivel

The optional TSP300 tilt and swivel manifold with robust interlocking design provides 360° X-axis rotation and 160° Y-axis rotation.

How to Order

Factory fitted to new W-Series (X-Edition) wrenches: Insert a "P" prior to the "X" in the tool designation, e.g.: **W2000PX**.

Order as an accessory using the part number: **TSP300**, which can be fitted to existing W-Series (X-Edition) wrenches.

Page: 225

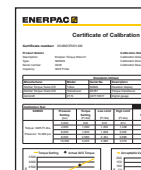

Calibration Certificate

All X-Edition tools are CE-ATEX declared, factory calibrated and are shipped complete with a calibration certificate.

  II 2 GD ck T4
CSA/SIRA 15XT072

W-Series, X-Edition Hexagon Wrenches

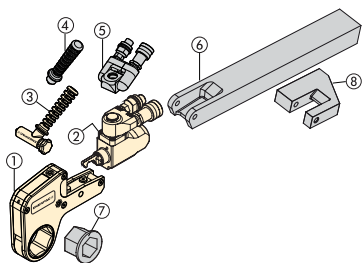

Hexagon Cassettes and Reducer Inserts
Full range of interchangeable hexagon cassettes and reducing inserts provides maximum versatility. Details available at www.enerpac.com

- ① Hexagon Cassette
- ② Drive Unit
- ③ Angled Positioning Handle
- ④ Straight Positioning Handle (optional)
- ⑤ Pro Series Swivel (optional)
- ⑥ Extended Reaction Arm (optional)
- ⑦ Reducer Insert (optional)
- ⑧ Reaction Paddle (optional)

DRIVE UNIT AND INTERCHANGEABLE CASSETTE SELECTION

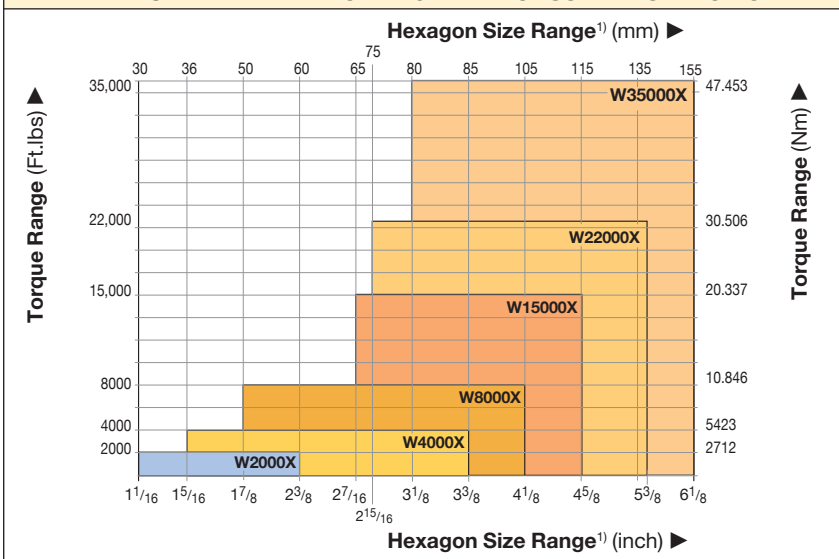

¹⁾ See page 285 for table of hexagon sizes of bolts, nuts and related thread diameters.

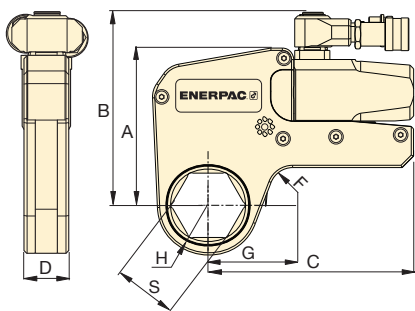

SELECTION CHART

Hexagon Range *	Nominal Torque at 10,000 psi		Drive Unit Model Number **	Minimum Torque		Dimensions (see pages 214-221 for dimensions H, G, and S)					Weight (Drive unit without hexagon cassette)	
	(in)	(mm)		(Ft.lbs)	(Nm)	(Ft.lbs)	(Nm)	A	B	C		D
1 1/16 - 2 3/8	30 - 60	2040	2766	W2000X	204	277	4.29	5.55	5.83	1.26	.79	3.04
1 5/16 - 3 3/8	36 - 85	4175	5661	W4000X	418	566	5.35	6.57	7.01	1.61	.79	4.44
1 7/8 - 4 1/8	50 - 105	8470	11,484	W8000X	847	1148	6.77	8.07	8.19	2.07	.98	6.59
2 7/16 - 4 5/8	65 - 115	15,330	20,785	W15000X	1533	2079	8.15	9.45	9.96	2.48	.79	10.72
2 15/16 - 5 3/8	75 - 135	22,500	30,506	W22000X	2250	3050	8.94	10.46	11.68	3.03	1.38	16.98
3 1/8 - 6 1/8	80-155	35,000	47,453	W35000X	3500	4745	10.54	11.94	13.60	3.57	1.98	26.40

* With in-line reaction foot.

** To order a W-series (X-Edition) wrench fitted with the TSP swivel, insert a "P" prior to the "X" in the tool designation. e.g., W2000PX.

W Series (X-Edition)



Nominal Torque at 10,000 psi:

35,000 Ft.lbs

Hexagon Range:

1 1/16 - 6 1/8 inch

Nose Radius:

1.22-4.52 inch

Maximum Operating Pressure:

10,000 psi



Torque Wrench Pump Selection Matrix

For optimum speed and performance see the torque wrench and pump matrix.

Page: **232**

▼ These rigid steel wrenches with low profile interchangeable hexagon cassettes guarantee durability and maximum versatility in bolting applications.



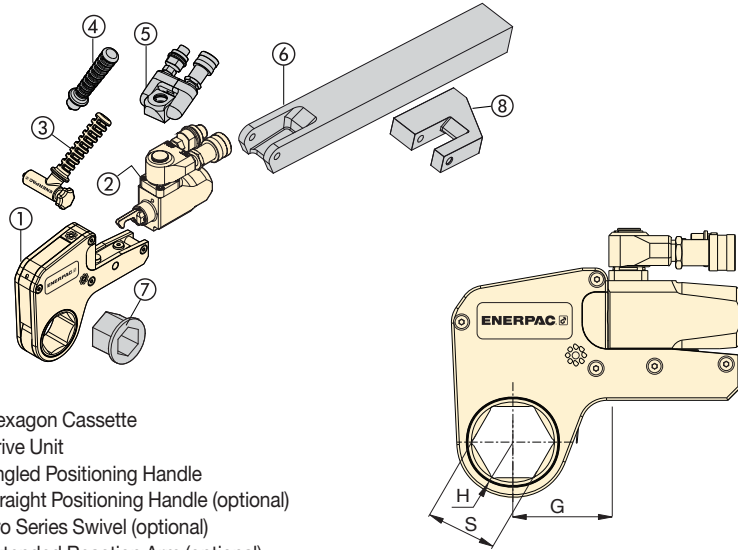

- ① Hexagon Cassette
- ② Drive Unit
- ③ Angled Positioning Handle
- ④ Straight Positioning Handle (optional)
- ⑤ Pro Series Swivel (optional)
- ⑥ Extended Reaction Arm (optional)
- ⑦ Reducer Insert (optional)
- ⑧ Reaction Paddle (optional)

W Series (X-Edition)



Nominal Torque at 10,000 psi:
2040 Ft.lbs

Hexagon Range:
1¹/₁₆ - 2³/₈ inch

Maximum Operating Pressure:
10,000 psi







Metric Sizes

For metric sizes of hexagon cassettes and reducer inserts see:

Page: **220**

▼ SELECTION CHART

Drive Unit Model Number	Hexagon Size	Nose Radius	Dim.	Model Number	Weight						
						Hexagon Reducer (in)	Model Number	Hexagon Reducer (in)	Model Number	Hexagon Reducer (in)	Model Number
W2000X	S (in)	H (in)	G (in)		(lbs)						
	1 ¹ / ₁₆	1.22	2.11	W2101X	4.19	-	-	-	-	-	-
	1 ¹ / ₈	1.22	2.11	W2102X	4.19	-	-	-	-	-	-
	1 ³ / ₁₆	1.22	2.11	W2103X	4.19	-	-	-	-	-	-
	1 ¹ / ₄	1.22	2.11	W2104X	4.19	-	-	-	-	-	-
	1 ⁵ / ₁₆	1.22	2.11	W2105X	4.48	-	-	-	-	-	-
	1 ³ / ₈	1.22	2.11	W2106X	4.43	-	-	-	-	-	-
	1 ⁷ / ₁₆	1.22	2.11	W2107X	4.37	1 ⁷ / ₁₆ - 1 ¹ / ₈	W2107R102	-	-	-	-
	1 ¹ / ₂	1.32	2.29	W2108X	4.51	-	-	-	-	-	-
	1 ⁹ / ₁₆	1.32	2.29	W2109X	4.44	-	-	-	-	-	-
	1 ⁵ / ₈	1.32	2.29	W2110X	4.38	1 ⁵ / ₈ - 1 ¹ / ₄	W2110R104	1 ⁵ / ₈ - 1 ³ / ₁₆	W2110R103	-	-
	1 ¹¹ / ₁₆	1.44	2.38	W2111X	4.63	-	-	-	-	-	-
	1 ³ / ₄	1.44	2.38	W2112X	4.57	-	-	-	-	-	-
	1 ¹³ / ₁₆	1.44	2.38	W2113X	4.46	1 ¹³ / ₁₆ - 1 ⁷ / ₁₆	W2113R107	1 ¹³ / ₁₆ - 1 ¹ / ₄	W2113R104	-	-
	1 ⁷ / ₈	1.54	2.48	W2114X	4.69	-	-	-	-	-	-
	1 ¹⁵ / ₁₆	1.54	2.48	W2115X	4.64	-	-	-	-	-	-
	2	1.54	2.48	W2200X	4.54	2 - 1 ⁵ / ₈	W2200R110	2 - 1 ⁷ / ₁₆	W2200R107	-	-
	2 ¹ / ₁₆	1.65	2.70	W2201X	4.83	-	-	-	-	-	-
	2 ¹ / ₈	1.65	2.70	W2202X	4.74	-	-	-	-	-	-
	2 ³ / ₁₆	1.65	2.70	W2203X	4.64	2 ³ / ₁₆ - 1 ¹³ / ₁₆	W2203R113	2 ³ / ₁₆ - 1 ⁵ / ₈	W2203R110	2 ³ / ₁₆ - 1 ⁷ / ₁₆	W2203R107
	2 ¹ / ₄	1.75	2.55	W2204X	4.94	-	-	-	-	-	-
2 ⁵ / ₁₆	1.75	2.55	W2205X	4.84	-	-	-	-	-	-	
2 ³ / ₈	1.75	2.55	W2206X	4.72	2 ³ / ₈ - 2	W2206R200	2 ³ / ₈ - 1 ⁷ / ₈	W2206R114	2 ³ / ₈ - 1 ¹³ / ₁₆	W2206R113	
-	-	-	-	-	-	2 ³ / ₈ - 1 ¹ / ₂	W2206R108	2 ³ / ₈ - 1 ⁷ / ₁₆	W2206R107	2 ³ / ₈ - 1 ⁵ / ₈	W2206R110

W4000X Series Imperial Cassettes & Reducer Inserts

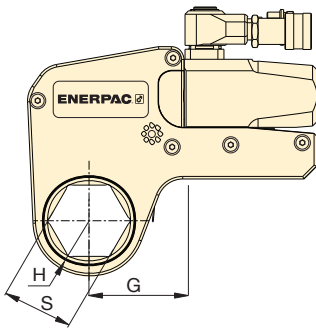

Nominal Torque at 10,000 psi:

4175 Ft.lbs

Hexagon Range:

1⁵/₁₆-3³/₈ inch

Maximum Operating Pressure:

10,000 psi

W
Series
(X-Edition)



▼ SELECTION CHART

Drive Unit Model Number	Hexagon Size	Nose Radius	Dim.	Model Number	Weight	Hexagon Reducer		Hexagon Reducer		Hexagon Reducer	
						Hexagon Reducer (in)	Model Number	Hexagon Reducer (in)	Model Number	Hexagon Reducer (in)	Model Number
W4000X	S (in)	H (in)	G (in)		(lbs)						
	1 ⁵ / ₁₆	1.46	2.40	W4105X	8.15	-	-	-	-	-	-
	1 ³ / ₈	1.46	2.40	W4106X	8.15	-	-	-	-	-	-
	1 ⁷ / ₁₆	1.46	2.40	W4107X	8.15	-	-	-	-	-	-
	1 ¹ / ₂	1.46	2.40	W4108X	8.31	-	-	-	-	-	-
	1 ⁹ / ₁₆	1.46	2.40	W4109X	8.22	-	-	-	-	-	-
	1 ⁵ / ₈	1.46	2.40	W4110X	8.15	-	-	-	-	-	-
	1 ¹¹ / ₁₆	1.56	2.52	W4111X	8.43	-	-	-	-	-	-
	1 ³ / ₄	1.56	2.52	W4112X	8.35	-	-	-	-	-	-
	1 ¹³ / ₁₆	1.56	2.52	W4113X	8.25	-	-	-	-	-	-
	1 ⁷ / ₈	1.63	2.63	W4114X	8.45	-	-	-	-	-	-
	1 ¹⁵ / ₁₆	1.63	2.63	W4115X	8.39	-	-	-	-	-	-
	2	1.63	2.63	W4200X	8.28	2 - 1 ⁷ / ₁₆	W4200R107	-	-	-	-
	2 ¹ / ₁₆	1.73	2.89	W4201X	8.65	-	-	-	-	-	-
	2 ¹ / ₈	1.73	2.89	W4202X	8.53	-	-	-	-	-	-
	2 ³ / ₁₆	1.73	2.89	W4203X	8.42	2 ³ / ₁₆ - 1 ⁵ / ₈	W4203R110	2 ³ / ₁₆ - 1 ⁷ / ₁₆	W4203R107	2 ³ / ₁₆ - 1 ¹ / ₄	W4203R104
	2 ¹ / ₄	1.83	2.78	W4204X	8.73	-	-	-	-	-	-
	2 ⁵ / ₁₆	1.83	2.78	W4205X	8.61	-	-	-	-	-	-
	2 ³ / ₈	1.83	2.78	W4206X	8.47	2 ³ / ₈ - 2	W4206R200	2 ³ / ₈ - 1 ¹³ / ₁₆	W4206R113	2 ³ / ₈ - 1 ⁷ / ₁₆	W4206R107
	-	-	-	-	-	2 ³ / ₈ - 1 ³ / ₈	W4206R106	-	-	-	-
	2 ⁷ / ₁₆	1.95	3.00	W4207X	8.96	2 ⁷ / ₁₆ - 2	W4207R200	-	-	-	-
	2 ¹ / ₂	1.95	3.00	W4208X	8.86	2 ¹ / ₂ - 2	W4208R200	2 ¹ / ₂ - 1 ¹³ / ₁₆	W4208R113	2 ¹ / ₂ - 2 ¹ / ₁₆	W4208R201
	2 ⁹ / ₁₆	1.95	3.00	W4209X	8.67	2 ⁹ / ₁₆ - 2 ³ / ₁₆	W4209R203	2 ⁹ / ₁₆ - 2 ¹ / ₈	W4209R202	-	-
	-	-	-	-	-	2 ⁹ / ₁₆ - 2	W4209R200	2 ⁹ / ₁₆ - 1 ¹³ / ₁₆	W4209R113	-	-
	2 ⁵ / ₈	2.07	3.08	W4210X	9.14	-	-	-	-	-	-
	2 ¹¹ / ₁₆	2.07	3.08	W4211X	9.03	-	-	-	-	-	-
	2 ³ / ₄	2.07	3.08	W4212X	8.84	2 ³ / ₄ - 2 ³ / ₈	W4212R206	2 ³ / ₄ - 2 ³ / ₁₆	W4212R203	2 ³ / ₄ - 2 ¹ / ₈	W4212R202
	2 ¹³ / ₁₆	2.18	3.21	W4213X	9.32	-	-	-	-	-	-
	2 ⁷ / ₈	2.18	3.21	W4214X	9.17	-	-	-	-	-	-
	2 ¹⁵ / ₁₆	2.18	3.21	W4215X	8.96	2 ¹⁵ / ₁₆ - 2 ⁹ / ₁₆	W4215R209	2 ¹⁵ / ₁₆ - 2 ³ / ₈	W4215R206	2 ¹⁵ / ₁₆ - 2 ³ / ₁₆	W4215R203
	-	-	-	-	-	2 ¹⁵ / ₁₆ - 2	W4215R200	-	-	-	-
	3	2.30	3.29	W4300X	9.51	3 - 2 ³ / ₁₆	W4300R203	-	-	-	-
3 ¹ / ₁₆	2.30	3.29	W4301X	9.42	-	-	-	-	-	-	
3 ¹ / ₈	2.30	3.29	W4302X	9.16	-	-	3 ¹ / ₈ - 2 ³ / ₄	W4302R212	3 ¹ / ₈ - 2 ⁹ / ₁₆	W4302R209	
-	-	-	-	-	3 ¹ / ₈ - 2 ³ / ₈	W4302R206	3 ¹ / ₈ - 2 ⁵ / ₁₆	W4302R205	3 ¹ / ₈ - 2 ¹ / ₄	W4302R204	
-	-	-	-	-	3 ¹ / ₈ - 2 ³ / ₁₆	W4302R203	3 ¹ / ₈ - 2 ¹ / ₈	W4302R202	3 ¹ / ₈ - 2	W4302R200	
3 ³ / ₁₆	2.44	3.37	W4303X	9.92	-	-	-	-	-	-	
3 ¹ / ₄	2.44	3.37	W4304X	9.92	-	-	-	-	-	-	
3 ⁵ / ₁₆	2.44	3.37	W4305X	9.92	-	-	-	-	-	-	
3 ³ / ₈	2.44	3.37	W4306X	9.92	-	-	-	-	-	-	

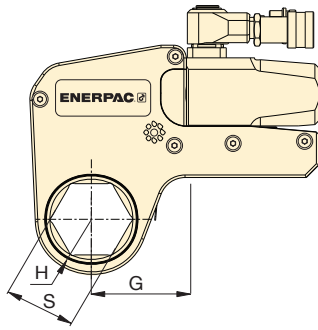

Nominal Torque at 10,000 psi:

8470 Ft.lbs

Hexagon Range:

1 7/8 - 4 1/8 inch





Maximum Operating Pressure:

10,000 psi

W
Series
(X-Edition)



▼ SELECTION CHART

Drive Unit Model Number	Hexagon Size	Nose Radius	Dim.	Model Number	Weight						
						Hexagon Reducer	Model Number	Hexagon Reducer	Model Number	Hexagon Reducer	Model Number
	S (in)	H (in)	G (in)		(lbs)	(in)		(in)		(in)	
W8000X	1 7/8	1.77	3.08	W8114X	17.97	-	-	-	-	-	-
	1 15/16	1.77	3.08	W8115X	17.89	-	-	-	-	-	-
	2	1.77	3.08	W8200X	17.75	-	-	-	-	-	-
	2 1/16	1.89	3.15	W8201X	17.52	-	-	-	-	-	-
	2 1/8	1.89	3.15	W8202X	17.36	-	-	-	-	-	-
	2 3/16	1.89	3.15	W8203X	17.22	-	-	-	-	-	-
	2 1/4	2.01	3.25	W8204X	17.92	-	-	-	-	-	-
	2 5/16	2.01	3.25	W8205X	17.76	-	-	-	-	-	-
	2 3/8	2.01	3.25	W8206X	17.59	-	-	-	-	-	-
	2 7/16	2.07	3.38	W8207X	17.65	-	-	-	-	-	-
	2 1/2	2.07	3.38	W8208X	17.52	-	-	-	-	-	-
	2 9/16	2.07	3.38	W8209X	17.29	2 9/16 - 2	W8209R200	-	-	-	-
	2 5/8	2.20	3.34	W8210X	17.50	-	-	-	-	-	-
	2 11/16	2.20	3.34	W8211X	17.36	-	-	-	-	-	-
	2 3/4	2.20	3.34	W8212X	17.12	2 3/4 - 2 3/16	W8212R203	-	-	-	-
	2 13/16	2.28	3.35	W8213X	17.57	-	-	-	-	-	-
	2 7/8	2.28	3.35	W8214X	17.38	-	-	-	-	-	-
	2 15/16	2.28	3.35	W8215X	17.11	2 15/16 - 2 3/8	W8215R206	2 15/16 - 2 3/8	W8215R203	-	-
	3	2.38	3.52	W8300X	17.77	-	-	-	-	-	-
	3 1/16	2.38	3.52	W8301X	17.65	-	-	-	-	-	-
	3 1/8	2.38	3.52	W8302X	17.33	3 1/8 - 2 9/16	W8302R209	3 1/8 - 2 3/8	W8302R206	3 1/8 - 2 3/16	W8302R203
	-	-	-	-	-	-	3 1/8 - 2	W8302R200	-	-	-
	3 3/16	2.60	3.63	W8303X	18.99	-	-	-	-	-	-
	3 1/4	2.60	3.63	W8304X	18.72	-	-	-	-	-	-
	3 5/16	2.60	3.63	W8305X	18.54	-	-	-	-	-	-
	3 3/8	2.60	3.63	W8306X	18.36	-	-	-	-	-	-
	3 7/16	2.60	3.63	W8307IX	18.11	-	-	-	-	-	-
	3 1/2	2.60	3.63	W8308X	17.81	3 1/2 - 3	W8308R300	3 1/2 - 2 15/16	W8308R215	3 1/2 - 2 3/4	W8308R212
	3 9/16	2.91	4.05	W8309X	20.36	-	-	-	-	-	-
	3 5/8	2.91	4.05	W8310X	20.18	-	-	-	-	-	-
	3 11/16	2.91	4.05	W8311X	19.93	-	-	-	-	-	-
	3 3/4	2.91	4.05	W8312X	19.71	3 3/4 - 3 1/8	W8312R302	3 3/4 - 2 15/16	W8312R215	3 3/4 - 2 3/4	W8312R212
3 13/16	2.91	4.05	W8313X	19.46	-	-	-	-	-	-	
3 7/8	2.91	4.05	W8314X	19.10	3 7/8 - 3 1/8	W8314R302	3 7/8 - 2 15/16	W8314R215	-	-	
3 15/16	3.13	4.33	W8315X	20.31	-	-	-	-	-	-	
4	3.13	4.33	W8400X	20.04	-	-	-	-	-	-	
4 1/16	3.13	4.33	W8401IX	19.80	-	-	-	-	-	-	
4 1/8	3.13	4.33	W8402X	19.39	-	-	-	-	-	-	

W15000X Series Imperial Cassettes & Reducer Inserts

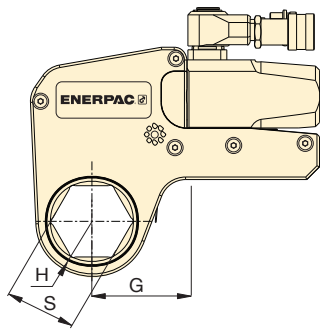

Nominal Torque at 10,000 psi:

15,330 Ft.lbs

Hexagon Range:

2⁷/₁₆-4⁵/₈ inch

Maximum Operating Pressure:

10,000 psi

W
Series
(X-Edition)



▼ SELECTION CHART

Drive Unit Model Number	Hexagon Size	Nose Radius	Dim.	Model Number	Weight	Hexagon Reducer		Hexagon Reducer		Hexagon Reducer	
						Hexagon Reducer	Model Number	Hexagon Reducer	Model Number	Hexagon Reducer	Model Number
	S (in)	H (in)	G (in)		(lbs)	(in)		(in)		(in)	
W15000X	2 ⁷ / ₁₆	2.32	3.49	W15207X	30.72	-	-	-	-	-	-
	2 ¹ / ₂	2.32	3.49	W15208X	30.72	-	-	-	-	-	-
	2 ⁹ / ₁₆	2.32	3.49	W15209X	30.72	-	-	-	-	-	-
	2 ⁵ / ₈	2.32	3.49	W15210X	30.72	-	-	-	-	-	-
	2 ¹¹ / ₁₆	2.32	3.49	W15211X	30.72	-	-	-	-	-	-
	2 ³ / ₄	2.32	3.49	W15212X	30.72	-	-	-	-	-	-
	2 ¹³ / ₁₆	2.44	3.56	W15213X	30.62	-	-	-	-	-	-
	2 ⁷ / ₈	2.44	3.56	W15214X	30.39	-	-	-	-	-	-
	2 ¹⁵ / ₁₆	2.44	3.56	W15215X	30.08	-	-	-	-	-	-
	3	2.54	3.66	W15300X	30.86	3 - 2 ¹ / ₈	W15300R202	-	-	-	-
	3 ¹ / ₁₆	2.54	3.66	W15301X	30.71	-	-	-	-	-	-
	3 ¹ / ₈	2.54	3.66	W15302X	30.34	3 ¹ / ₈ - 2 ⁹ / ₁₆	W15302R209	-	-	-	-
	3 ³ / ₁₆	2.74	3.80	W15303X	32.38	-	-	-	-	-	-
	3 ¹ / ₄	2.74	3.80	W15304X	32.07	-	-	-	-	-	-
	3 ⁵ / ₁₆	2.74	3.80	W15305X	31.85	-	-	-	-	-	-
	3 ³ / ₈	2.74	3.80	W15306X	31.63	-	-	-	-	-	-
	3 ⁷ / ₁₆	2.74	3.80	W15307IX	31.32	-	-	-	-	-	-
	3 ¹ / ₂	2.74	3.80	W15308X	30.98	3 ¹ / ₂ - 2 ¹⁵ / ₁₆	W15308R215	3 ¹ / ₂ - 2 ³ / ₄	W15308R212	-	-
	3 ⁹ / ₁₆	2.95	4.01	W15309X	31.70	-	-	-	-	-	-
	3 ⁵ / ₈	2.95	4.01	W15310X	31.70	-	-	-	-	-	-
	3 ¹¹ / ₁₆	2.95	4.01	W15311X	31.70	-	-	-	-	-	-
	3 ³ / ₄	2.95	4.01	W15312X	31.70	3 ³ / ₄ - 3 ¹ / ₈	W15312R302	3 ³ / ₄ - 2 ¹⁵ / ₁₆	W15312R215	-	-
	3 ¹³ / ₁₆	2.95	4.01	W15313X	31.70	-	-	-	-	-	-
	3 ⁷ / ₈	2.95	4.01	W15314X	31.70	3 ⁷ / ₈ - 3 ¹ / ₈	W15314R302	3 ⁷ / ₈ - 2 ¹⁵ / ₁₆	W15314R215	-	-
	3 ¹⁵ / ₁₆	3.17	4.06	W15315X	34.02	-	-	-	-	-	-
	4	3.17	4.06	W15400X	33.70	-	-	-	-	-	-
	4 ¹ / ₁₆	3.17	4.06	W15401IX	33.41	-	-	-	-	-	-
	4 ¹ / ₈	3.17	4.06	W15402X	33.09	4 ¹ / ₈ - 3 ¹ / ₂	W15402R308	4 ¹ / ₈ - 3 ⁵ / ₁₆	W15402R305	4 ¹ / ₈ - 3 ¹ / ₄	W15402R304
	4 ³ / ₁₆	3.17	4.06	W15403IX	32.81	-	-	-	-	-	-
	4 ¹ / ₄	3.17	4.06	W15404X	32.29	4 ¹ / ₄ - 3 ¹ / ₂	W15404R308	4 ¹ / ₄ - 3 ¹ / ₈	W15404R302	-	-
	4 ⁵ / ₁₆	3.44	4.52	W15405X	35.61	-	-	-	-	-	-
	4 ³ / ₈	3.44	4.52	W15406X	35.32	-	-	-	-	-	-
4 ⁷ / ₁₆	3.44	4.52	W15407X	34.99	-	-	-	-	-	-	
4 ¹ / ₂	3.44	4.52	W15408IX	34.63	-	-	-	-	-	-	
4 ⁹ / ₁₆	3.44	4.52	W15409IX	34.28	-	-	-	-	-	-	
4 ⁵ / ₈	3.44	4.52	W15410IX	33.72	4 ⁵ / ₈ - 3 ¹⁵ / ₁₆	W15410R315	4 ⁵ / ₈ - 3 ⁷ / ₈	W15410R314	4 ⁵ / ₈ - 3 ³ / ₄	W15410R312	
-	-	-	-	-	-	4 ⁵ / ₈ - 3 ¹ / ₂	W15410R308	-	-	-	

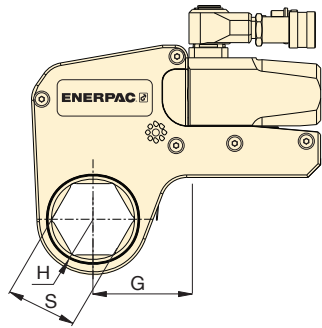

Nominal Torque at 10,000 psi:

22,500 Ft.lbs

Hexagon Range:

2¹⁵/₁₆ - 5³/₈ inch



Maximum Operating Pressure:

10,000 psi

W
Series
(X-Edition)





▼ SELECTION CHART

Drive Unit Model Number	Hexagon Size	Nose Radius	Dim.	Model Number	Weight						
						Hexagon Reducer (in)	Model Number	Hexagon Reducer (in)	Model Number	Hexagon Reducer (in)	Model Number
W22000X	2¹⁵/₁₆	2.64	4.02	W22215X	48.72	-	-	-	-	-	-
	3	2.64	4.02	W22300X	48.40	-	-	-	-	-	-
	3¹/₁₆	2.64	4.02	W22301X	48.22	-	-	-	-	-	-
	3¹/₈	2.64	4.02	W22302X	47.78	3 ¹ / ₈ - 2 ³ / ₈	W22302R206	3 ¹ / ₈ - 2 ³ / ₁₆	W22302R203	-	-
	3³/₁₆	2.85	4.23	W22303X	50.58	-	-	-	-	-	-
	3¹/₄	2.85	4.23	W22304X	50.19	-	-	-	-	-	-
	3⁵/₁₆	2.85	4.23	W22305X	49.92	-	-	-	-	-	-
	3³/₈	2.85	4.23	W22306X	49.66	-	-	-	-	-	-
	3⁷/₁₆	2.85	4.23	W22307X	50.29	-	-	-	-	-	-
	3¹/₂	2.85	4.23	W22308X	48.87	3 ¹ / ₂ - 2 ³ / ₄	W22308R212	3 ¹ / ₂ - 2 ⁹ / ₁₆	W22308R209	3 ¹ / ₂ - 2 ³ / ₈	W22308R206
	3⁹/₁₆	3.07	4.45	W22309X	51.58	-	-	-	-	-	-
	3⁵/₈	3.07	4.45	W22310X	51.30	-	-	-	-	-	-
	3¹¹/₁₆	3.07	4.45	W22311X	50.93	-	-	-	-	-	-
	3³/₄	3.07	4.45	W22312X	50.62	3 ³ / ₄ - 2 ¹⁵ / ₁₆	W22312R215	-	-	-	-
	3¹³/₁₆	3.07	4.45	W22313X	50.24	-	-	-	-	-	-
	3⁷/₈	3.07	4.45	W22314X	49.77	3 ⁷ / ₈ - 3 ¹ / ₈	W22314R302	3 ⁷ / ₈ - 2 ¹⁵ / ₁₆	W22314R215	3 ⁷ / ₈ - 2 ³ / ₄	W22314R212
	3¹⁵/₁₆	3.35	4.72	W22315X	53.57	-	-	-	-	-	-
	4	3.35	4.72	W22400X	53.19	-	-	-	-	-	-
	4¹/₁₆	3.35	4.72	W22401IX	52.82	-	-	-	-	-	-
	4¹/₈	3.35	4.72	W22402X	52.43	-	-	-	-	-	-
	4³/₁₆	3.35	4.72	W22403X	52.09	-	-	-	-	-	-
	4¹/₄	3.35	4.72	W22404X	51.48	4 ¹ / ₄ - 3 ¹ / ₂	W22404R308	4 ¹ / ₄ - 3 ¹ / ₈	W22404R302	4 ¹ / ₄ - 2 ¹⁵ / ₁₆	W22404R215
	4⁵/₁₆	3.54	4.92	W22405X	54.26	-	-	-	-	-	-
	4³/₈	3.54	4.92	W22406X	53.91	-	-	-	-	-	-
	4⁷/₁₆	3.54	4.92	W22407X	53.50	-	-	-	-	-	-
	4¹/₂	3.54	4.92	W22408IX	53.06	-	-	-	-	-	-
	4⁹/₁₆	3.54	4.92	W22409X	52.64	-	-	-	-	-	-
	4⁵/₈	3.54	4.92	W22410IX	51.99	4 ⁵ / ₈ - 3 ⁷ / ₈	W22410R314	4 ⁵ / ₈ - 3 ³ / ₄	W22410R312	4 ⁵ / ₈ - 3 ¹ / ₂	W22410R308
	4³/₄	3.74	5.12	W22412X	54.54	-	-	-	-	-	-
	4⁷/₈	3.74	5.12	W22414X	53.60	-	-	-	-	-	-
	5	3.74	5.12	W22500X	52.37	5 - 4 ¹ / ₄	W22500R404	5 - 4 ¹ / ₈	W22500R402	5 - 3 ⁷ / ₈	W22500R314
	5¹/₈	3.94	5.31	W22502X	55.10	-	-	-	-	-	-
5¹/₁₆	3.94	5.31	W22503X	54.71	-	-	-	-	-	-	
5¹/₄	3.94	5.31	W22504X	54.05	-	-	-	-	-	-	
5³/₈	3.94	5.31	W22506X	52.77	5 ³ / ₈ - 4 ⁵ / ₈	W22506R410	5 ³ / ₈ - 4 ¹ / ₄	W22506R404	5 ³ / ₈ - 4 ¹ / ₈	W22506R402	
-	-	-	W22506X	52.77	5 ³ / ₈ - 3 ⁷ / ₈	W22506R314	-	-	-	-	

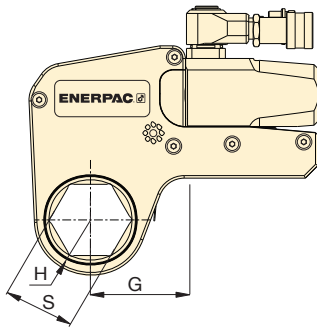
W35000X Series Imperial Cassettes & Reducer Inserts



▼ SELECTION CHART

Drive Unit Model Number	Hexagon Size	Nose Radius	Dim.	Model Number	Weight		
						Hexagon Reducer (in)	Model Number
W35000X	S (in)	H (in)	G (in)		(lbs)		
	3 ¹ / ₈	3.02	4.99	W35302X	72.30	3 ¹ / ₈ - 2	W35302R200
	3 ³ / ₁₆	3.02	4.99	W35303X	72.10	-	-
	3 ¹ / ₄	3.02	4.99	W35304X	71.70	-	-
	3 ⁵ / ₁₆	3.02	4.99	W35305X	71.40	-	-
	3 ³ / ₈	3.02	4.99	W35306X	71.00	-	-
	3 ⁷ / ₁₆	3.02	4.99	W35307IX	70.50	-	-
	3 ¹ / ₂	3.02	4.99	W35308X	70.10	3 ¹ / ₂ - 2 ⁵ / ₁₆	W35308R205
	3 ⁹ / ₁₆	3.23	5.22	W35309X	71.40	-	-
	3 ⁵ / ₈	3.23	5.22	W35310X	73.40	-	-
	3 ¹¹ / ₁₆	3.23	5.22	W35311X	73.00	-	-
	3 ³ / ₄	3.23	5.22	W35312X	72.50	-	-
	3 ¹³ / ₁₆	3.23	5.22	W35313X	72.10	-	-
	3 ⁷ / ₈	3.23	5.22	W35314X	71.40	3 ⁷ / ₈ - 2 ¹¹ / ₁₆	W35314R211
	3 ¹⁵ / ₁₆	3.45	5.39	W35315X	70.80	3 ¹⁵ / ₁₆ - 2 ¹³ / ₁₆	W35315R213
	4	3.45	5.39	W35400X	74.70	-	-
	4 ¹ / ₁₆	3.45	5.39	W35401X	74.30	-	-
	4 ¹ / ₈	3.45	5.39	W35402X	73.90	-	-
	4 ³ / ₁₆	3.45	5.39	W35403X	73.40	-	-
	4 ¹ / ₄	3.45	5.39	W35404X	72.80	4 ¹ / ₄ - 3 ¹³ / ₁₆	W35404R301
	4 ⁵ / ₁₆	3.69	5.63	W35405X	76.90	-	-
	4 ³ / ₈	3.69	5.63	W35406X	76.50	-	-
	4 ⁷ / ₁₆	3.69	5.63	W35407X	76.10	-	-
	4 ¹ / ₂	3.69	5.63	W35408X	75.60	-	-
	4 ⁹ / ₁₆	3.69	5.63	W35409IX	75.20	-	-
	4 ⁵ / ₈	3.69	5.63	W35410IX	74.50	4 ⁵ / ₈ - 3 ⁵ / ₈	W35410R310
	4 ³ / ₄	3.91	5.85	W35412X	78.50	4 ³ / ₄ - 3 ³ / ₄	W35412R312
	4 ⁷ / ₈	3.91	5.85	W35414X	76.90	-	-
	5	3.91	5.85	W35500X	75.60	5 - 4	W35500R400
	5 ¹ / ₈	4.09	6.02	W35502X	78.90	5 ¹ / ₈ - 4 ¹ / ₈	W35502R402
	5 ³ / ₁₆	4.09	6.02	W35503X	78.50	-	-
	5 ¹ / ₄	4.09	6.02	W35504X	77.60	-	-
5 ³ / ₈	4.09	6.02	W35506X	76.30	5 ³ / ₈ - 4 ⁵ / ₁₆	W35506R405	
5 ¹ / ₂	4.31	6.24	W35508X	79.80	-	-	
5 ⁹ / ₁₆	4.31	6.24	W35509X	79.40	-	-	
5 ⁵ / ₈	4.31	6.24	W35510X	78.50	-	-	
5 ³ / ₄	4.31	6.24	W35512X	76.90	5 ³ / ₄ - 4 ³ / ₄	W35512R412	
5 ⁷ / ₈	4.52	6.46	W35514X	80.90	5 ⁷ / ₈ - 4 ⁷ / ₈	W35514R414	
6	4.52	6.46	W35600X	79.60	-	-	
6 ¹ / ₈	4.52	6.46	W35602X	77.80	6 ¹ / ₈ - 5 ¹ / ₈	W35602R502	

W Series (X-Edition)



Nominal Torque at 10,000 psi:

35,000 Ft.lbs

Hexagon Range:

3¹/₈-6¹/₈ inches

Maximum Operating Pressure:

10,000 psi

W-Series Metric Cassettes and Reducer Inserts

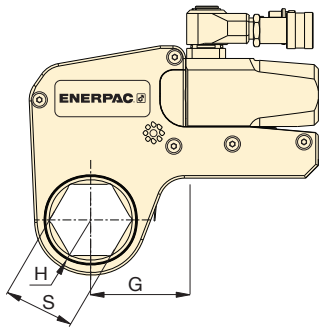





Hexagon Range:
30-105 mm

Maximum Operating Pressure:
10,000 psi (690 bar)

W
Series
(X-Edition)



▼ SELECTION CHART

Drive Unit Model Number	Hexagon Size	Nose Radius	Dim.	Model Number	Wt.							
						Hexagon Reducer	Model Number	Hexagon Reducer	Model Number	Hexagon Reducer	Model Number	
	S (mm)	H (in)	G (in)		(lbs)	(mm)		(mm)		(mm)		
W2000X	30	1.22	2.11	W2103X	4.19	-	-	-	-	-	-	
	32	1.22	2.11	W2104X	4.19	-	-	-	-	-	-	
	36	1.22	2.11	W2107X	4.19	-	-	-	-	-	-	
	38	1.32	2.29	W2108X	4.51	-	-	-	-	-	-	
	41	1.32	2.29	W2110X	4.38	41 - 32	W2110R104	41 - 30	W2110R103	41 - 24	W2110R024M	
	46	1.44	2.38	W2113X	4.69	46 - 36	W2113R107	46 - 32	W2113R104	-	-	
	50	1.54	2.48	W2200X	4.54	50 - 41	W2200R110	50 - 36	W2200R107	-	-	
	55	1.65	2.70	W2203X	4.64	55 - 46	W2203R113	55 - 41	W2203R110	55 - 36	W2203R107	
	60	1.75	2.55	W2206X	4.72	60 - 50	W2206R200	60 - 46	W2206R113	60 - 41	W2206R110	
-	-	-	-	-	-	60 - 36	W2206R107	-	-	-	-	
W4000X	36	1.46	2.40	W4107X	7.72	-	-	-	-	-	-	
	41	1.46	2.40	W4110X	7.72	-	-	-	-	-	-	
	46	1.56	2.52	W4113X	7.94	-	-	-	-	-	-	
	50	1.63	2.63	W4200X	8.28	50 - 36	W4200R107	-	-	-	-	
	55	1.73	2.89	W4203X	8.42	55 - 41	W4203R110	55 - 36	W4203R107	55 - 32	W4203R104	
	60	1.83	2.78	W4206X	8.47	60 - 50	W4206R200	60 - 46	W4206R113	60 - 36	W4206R107	
	65	1.95	3.00	W4209X	8.67	65 - 55	W4209R203	65 - 50	W4209R200	65 - 46	W4209R113	
	70	2.07	3.08	W4212X	8.84	70 - 60	W4212R206	70 - 55	W4212R203	-	-	
	75	2.18	3.21	W4215X	8.96	75 - 65	W4215R209	75 - 60	W4215R206	-	-	
	-	-	-	-	-	-	75 - 55	W4215R203	75 - 50	W4215R200	-	-
	80	2.30	3.29	W4302X	9.16	80 - 75	W4302R215	80 - 70	W4302R212	80 - 65	W4302R209	
	-	-	-	-	-	-	80 - 55	W4302R203	80 - 50	W4302R200	-	-
W8000X	50	1.77	3.08	W8200X	17.75	-	-	-	-	-	-	
	55	1.89	3.15	W8203X	17.22	-	-	-	-	-	-	
	60	2.01	3.25	W8206X	17.59	-	-	-	-	-	-	
	65	2.07	3.38	W8209X	17.29	65 - 50	W8209R200	-	-	-	-	
	70	2.07	3.34	W8212X	17.12	70 - 55	W8212R203	-	-	-	-	
	75	2.28	3.35	W8215X	17.11	75 - 60	W8215R206	75 - 55	W8215R203	-	-	
	80	2.38	3.52	W8302X	17.33	80 - 65	W8302R209	80 - 60	W8302R206	80 - 55	W8302R203	
	-	-	-	-	-	-	80 - 50	W8302R200	-	-	-	
	85	2.60	3.63	W8085MX	18.42	85 - 70	W8085R070M	85 - 65	W8085R065M	85 - 60	W8085R060M	
	-	-	-	-	-	-	85 - 55	W8085R055M	-	-	-	
	90	2.91	4.05	W8090MX	20.46	90 - 75	W8090R075M	-	-	-	-	
	95	2.91	4.05	W8312X	19.71	95 - 80	W8312R302	95 - 75	W8312R215	-	-	
	100	3.13	4.33	W8315X	20.31	-	-	-	-	-	-	
105	3.13	4.33	W8402X	19.39	-	-	-	-	-	-		

W-Series Metric Cassettes and Reducer Inserts

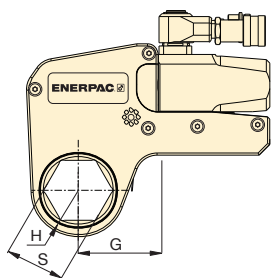

Hexagon Range:

65-155 mm

Maximum Operating Pressure:

10,000 psi (690 bar)

W
Series
(X-Edition)



▼ SELECTION CHART

Drive Unit Model Number	Hexagon Size	Nose Radius	Dim.	Model Number	Wt.	Hexagon Reducer		Hexagon Reducer	
						Hexagon Reducer (mm)	Model Number	Hexagon Reducer (mm)	Model Number
	S (mm)	H (in)	G (in)		(lbs)				
W15000X	65	2.32	3.49	W15209X	30.72	-	-	-	-
	70	2.32	3.49	W15212X	30.72	-	-	-	-
	75	2.44	3.56	W15215X	30.08	-	-	-	-
	80	2.54	3.66	W15302X	30.34	80-65	W15302R209	-	-
	85	2.74	3.80	W15085MX	31.70	85-70	W15085R070M	-	-
	90	2.95	4.01	W15090MX	33.32	90-75	W15090R075M	-	-
	95	2.95	4.01	W15312X	31.70	95-80	W15312R302	95 - 75	W15312R215
	100	3.17	4.06	W15315X	34.02	-	-	-	-
	105	3.17	4.06	W15402X	33.09	105-90	W15402R090M	-	-
	110	3.44	4.52	W15405X	35.61	110-95	W15110R095M	-	-
	115	3.44	4.52	W15115MX	34.48	115-100	W15115R100M	-	-
W22000X	75	2.64	4.02	W22215X	48.72	-	-	-	-
	80	2.64	4.02	W22302X	47.78	80-60	W22302R206	80 - 55	W22302R203
	85	2.85	4.23	W22085MX	49.74	85-65	W22085MR209	85 - 60	W22085MR206
	90	3.07	4.45	W22090MX	51.72	90-70	W22090M212	90 - 60	W22090MR206
	95	3.07	4.45	W22312X	50.62	95-75	W22312R215	-	-
	100	3.35	4.72	W22315X	53.57	-	-	-	-
	105	3.35	4.72	W22402X	52.09	-	-	-	-
	110	3.54	4.92	W22404X	51.48	-	-	-	-
	115	3.54	4.92	W22115MX	52.88	-	-	-	-
	120	3.74	5.12	W22412X	54.54	-	-	-	-
	123	3.74	5.12	W22123MX	53.80	-	-	-	-
	130	3.94	5.31	W22502X	55.10	-	-	-	-
	135	3.94	5.31	W22506X	52.77	135 - 105	W22506R402	-	-
W35000X	80	3.02	5.08	W35302X	72.30	80-50	W35302R200	-	-
	85	3.02	5.08	W35085MX	33.10	-	-	-	-
	90	3.23	5.33	W35090MX	34.30	90-60	W35090R206	-	-
	95	3.23	5.30	W35312X	72.50	-	-	-	-
	100	3.45	5.48	W35315X	70.80	-	-	-	-
	105	3.45	5.48	W35402X	73.90	-	-	-	-
	110	3.69	5.75	W35405X	76.90	110-85	W35405R085M	-	-
	115	3.69	5.75	W35115MX	77.10	-	-	-	-
	120	3.91	6.01	W35412X	78.50	120-95	W35412R312	-	-
	123	3.91	6.01	W35123MX	78.90	-	-	-	-
	130	4.09	6.30	W35502X	78.90	130-105	W35502R402	-	-
	135	4.09	6.30	W35506X	76.30	135-110	W35506R405	-	-
	140	4.31	6.43	W35508X	79.80	140-115	W35508R115M	-	-
	145	4.31	6.43	W35512X	76.90	145-120	W35512R412	-	-
	150	4.52	6.67	W35514X	80.90	-	-	-	-
	151	4.52	6.67	W35151MX	82.10	-	-	-	-
	155	4.52	6.67	W35602X	77.80	155-130	W35602R502	-	-

▼ Shown: W4206SL stepped-width cassette with W4000X drive unit



Your easy and long lasting solution to difficult access bolting applications



Designed for Tight Spots

Stepped width design provides easy access in confined areas. UltraSlim cassettes fit where standard solutions won't.



Built to Outperform

High endurance components keep working when others fail.



Top Mounted Handles

Standard top mounted handles provide safety and versatility; optional angled handles are also available.

Replacement handle (straight)	SWH6S
Angled handle (optional)	SWH6A

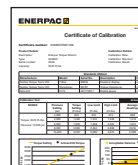

Calibration Certificate

All UltraSlim Series cassettes are CE - ATEX declared, factory calibrated and are shipped complete with a calibration certificate.

CE  II 2 GD ck T4
CSA/SIRA 15XT072

Versatility

- Lean, stepped width design allows tool to be mounted over bolts where other tools won't fit
- Bi-Hexagonal cassette allows twice as many positioning points on nut or bolt
- Uses same drive unit as standard W-series hexagon cassettes
- Robust top mounted handle stays out of the way, providing safe fastening in hard to reach areas

Performance

- Premium components provide best-in-class endurance

Ease of Use

- Few moving parts are easily accessible for quick field maintenance
- Fast release drive unit enables rapid exchange of cassettes, no tools required and no pins to lose
- Uses same drive unit as standard and X-Edition cassettes

Accuracy

- Constant torque output provides accuracy of +/- 3% across the full stroke

Slim enough to fit and tough enough to last. This UltraSlim wrench is the perfect controlled bolting solution for this oil and gas flange. ▶



UltraSlim Stepped-Width Cassettes



UltraSlim Stepped-Width Cassettes

Accessing narrow spaces normally requires significantly reducing the width of the torque wrench. For the tool operator, this has always meant vastly reduced tool durability, and/or reduced torque output.

By using the highest grade materials, perfecting the geometry, and placing the positioning handle on top of the tool, Enerpac UltraSlim cassettes are able to provide greater torque, get into tighter spaces, and vastly outperform the competition in product durability.*

Durability of Key Components*

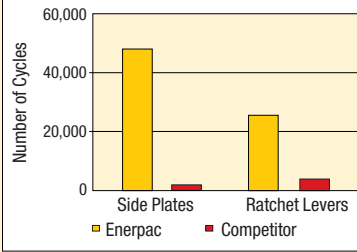

*Average test results, whereby three Enerpac 1³/₁₆" UltraSlim cassettes and three competitor 1³/₁₆" cassettes were tested at 4000 ft-lbs for 50,000 cycles. The Enerpac sideplates never broke for the full duration of the test.

W Series Ultra-Slim



Nominal Torque at 10,000 psi:

4360 Ft.lbs.

Hexagon Range:

1¹³/₁₆ - 2¹⁵/₁₆ inches

Maximum Operating Pressure:

10,000 psi



Torque Wrench Pumps

Visit enerpac.com for system matched air and electric torque wrench pumps that are ideal for use with hydraulic torque wrenches.

Page: 232



Torque Wrench Hoses

Use Enerpac THQ-700 Series hoses with W-Series torque wrenches to ensure the integrity of your hydraulic system.

19.5 feet long, 2 hoses	THQ-706T
39 feet long, 2 hoses	THQ-712T

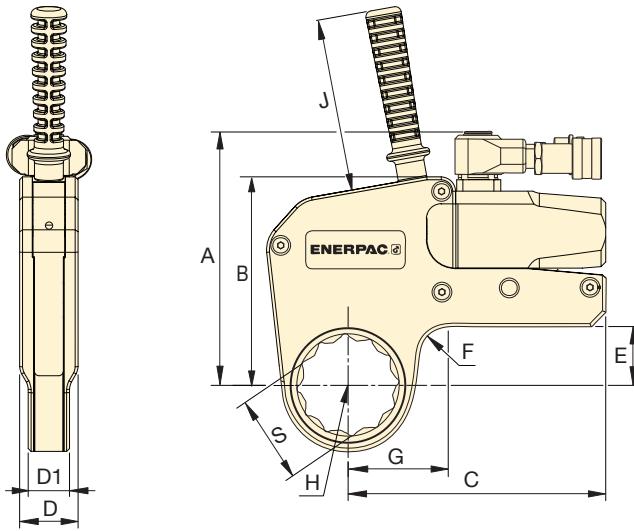

▼ SELECTION CHART

Hexagon Size	Nominal Torque @ 10,000 psi	Cassette Model Number	Minimum Torque @ 1000 psi	Nose Radius	Dimensions (in)									Weight (lbs)	Drive Unit Model* (sold separately)	
					G	A	B	C	D	D1	E	F (radius)	J			
S (in)	(Ft.lbs)		(Ft.lbs)	H (in)												
1 ¹³ / ₁₆	1980	W2113SL	200	1.44	2.35										4.87	W2000X
2 ⁹ / ₁₆	1980	W2203SL	200	1.63	2.49	5.54	4.30	5.81	1.28	1.00	0.94	0.79	4.72	4.87		
2 ³ / ₈	1980	W2206SL	200	1.75	2.56									4.88		
2 ⁹ / ₁₆	4360	W4203SL	430	1.73	2.70									10.15	W4000X	
2 ³ / ₈	4360	W4206SL	430	1.89	2.82									10.36		
2 ⁹ / ₁₆	4360	W4209SL	430	1.99	2.92	6.91	5.69	7.03	1.59	1.13	1.61	0.79	4.72	10.37		
2 ³ / ₄	4360	W4212SL	430	2.11	2.98									10.42		
2 ¹⁵ / ₁₆	4360	W4215SL	430	2.20	2.99									10.37		

* May also be used with **W2000PX** and **W4000PX** drive units, featuring double-swivel manifolds.

▼ WCR4000 Roller Cassette with Spanner and W4000 Drive Unit



WCR Series

Bi-Hexagonal Spanner Size:

1⁷/₁₆-3¹/₈ inch

Spanner Nose Radius:

1.22-2.18 inch

Nominal Torque:

4250 Ft-lbs

Maximum Operating Pressure:

10,000 psi



WCR4000 Torque Wrench

The **WCR4000** combines power and durability with a slim spanner design to provide bolting professionals with one of the most versatile and high performing limited access tools on the market today.

The tool was designed for use in narrow access applications, particularly in the height above the nut, and between the bolt center, and the inside of the joint.

Ideal for bolting API flanges, the **WCR4000** is available with a wide range of ring type spanners, and is powered by the standard W4000X drive unit.

- **Spanners available to fit most commonly used API flanges**
- **Small nose radius – resolves bolt to pipe restrictions**
- **Slim spanner design – reduces bolt height restrictions**
- **Wide range of spanners ranging from 1⁷/₁₆ - 3¹/₈ inches (36 - 80 mm)**
- **Includes handle to improve tool handling and safety**
- **Rigid solid steel body for maximum endurance and minimum downtime**

Closed Spanner Hexagon Size		Closed Spanner Model Number	Spanner Radius R (in)	Weight * (lb)	Roller Cassette Assy Model No.**	Drive Unit Model No.
S (in)	S (mm)					
1 ⁷ / ₁₆	36	W4107CS	1.22	4.2	WCR4000	W4000X
1 ¹ / ₂	38	W4108CS	1.29	4.4		
1 ⁵ / ₈	41	W4110CS	1.29	4.2		
1 ¹³ / ₁₆	46	W4113CS	1.40	4.3		
1 ⁷ / ₈	48	W4114CS	1.51	4.7		
2	50	W4200CS	1.51	4.2		
2 ⁹ / ₁₆	55	W4203CS	1.62	4.3		
2 ³ / ₈	60	W4206CS	1.77	4.6		
2 ⁹ / ₁₆	65	W4209CS	1.84	4.6		
2 ³ / ₄	70	W4212CS	1.95	4.7		
2 ¹⁵ / ₁₆	75	W4215CS	2.05	4.6		
3 ¹ / ₈	80	W4302CS	2.18	4.9		

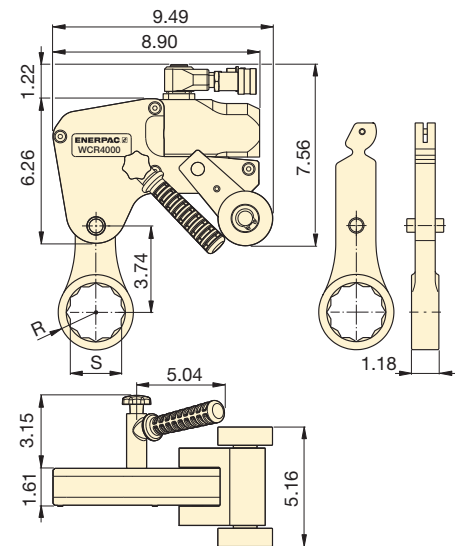

*For total weight add 13.89 lbs for WCR4000, 4.40 lbs. for W4000X and weight of the spanner.

** The WCR4000 cassettes, spanners and drive units are all sold separately.

Accessories for W-Series, X-Edition Torque Wrenches

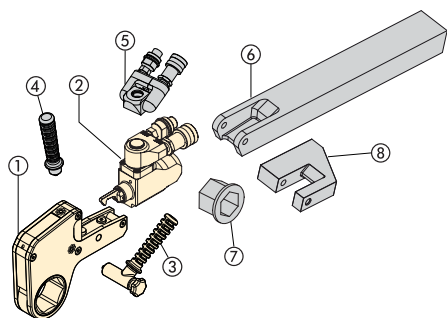

- ① Hexagon Cassette
- ② Drive Unit
- ③ Angled Positioning Handle
- ④ Straight Positioning Handle (optional)
- ⑤ Pro Series Swivel (optional)
- ⑥ Extended Reaction Arm (optional)
- ⑦ Reducer Insert (optional)
- ⑧ Reaction Paddle (optional)

**TSP
WTE
WRP
Series**



TSP-Series, Pro Series Swivels

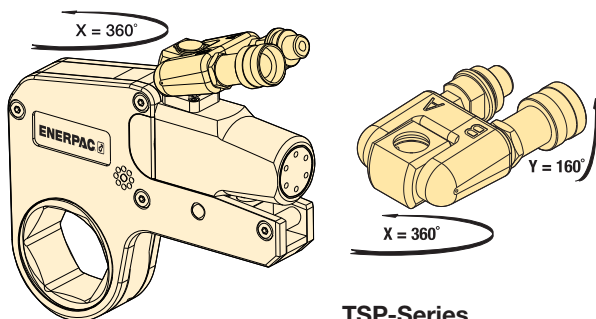

- Robust interlocking design
- 360° X-axis and 160° Y-axis rotation
- Increases tool fit in restricted access areas
- Simplifies hose placement
- Includes male and female couplers

Torque Wrench Model Number	Model Number	Maximum Pressure (psi)	Wt. (lbs)
W2000X, W4000X, W8000X, W15000X, W22000X, W35000X	TSP300*	10,000	.44

Note: To order a W-series (X-Edition) wrench fitted with the TSP swivel, insert a "P" prior to the "X" in the tool designation, e.g., W2000PX.

* TSP300 is designed for X-Edition tools only, and is not compatible with standard edition tools. For replacement components for existing tools, refer to repair sheet on www.enerpac.com

WTE-Series, Extended Reaction Arm

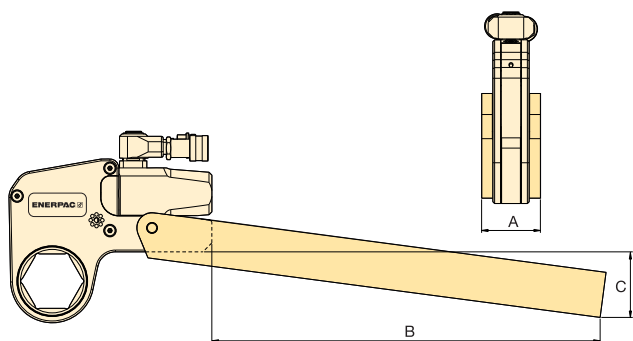

WTE-Series

- Full torque rated
- Increases tool fit in restricted access areas

Torque Wrench Model Number	Model Number	Dimensions (in)			Wt.* (lbs)
		A	B	C	
W2000X	WTE20	2.20	15.67	2.66	5.73
W4000X	WTE40	2.60	17.17	2.91	10.14
W8000X	WTE80	3.35	17.68	2.15	16.76
W15000X	WTE150	4.02	19.61	2.83	26.46
W22000X	WTE220	4.49	20.51	3.03	38.14
W35000X	WTE350	5.00	16.48	5.23	39.24

* Weights indicated are for the accessories only and do not include the wrench.

WRP-Series Reaction Paddles

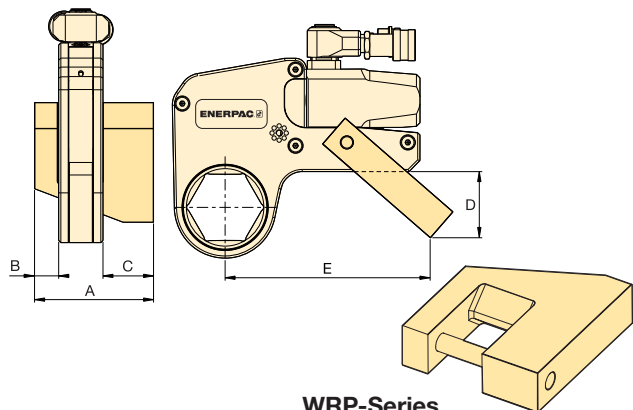

WRP-Series

- Lightweight interchangeable design
- Allows for offset reaction when in-line reaction is not available

Torque Wrench Model Number	Model Number	Dimensions (in)					Wt.* (lbs)
		A	B	C	D	E	
W2000X	WRP20	3.31	0.63	1.40	1.77	5.83	.88
W4000X	WRP40	4.29	0.83	1.87	2.32	7.48	1.76
W8000X	WRP80	5.37	1.02	2.25	2.72	8.78	4.41
W15000X	WRP150	6.50	1.26	2.74	3.43	10.12	8.60
W22000X	WRP220	8.15	1.52	3.58	5.28	12.48	15.87
W35000X	WRP350	9.22	1.79	3.58	7.17	13.98	23.37

* Weights indicated are for the accessories only and do not include the wrench.