

DESCRIPTION

- AP-20 is a high pressure hydraulic gear pump with cast iron end caps and an aluminum housing.
- Standard mounting flange is **SAE A-2 bolt**.
- Standard ports are **SAE-12 inlet** and **SAE-10 outlet**. Hang options available. Consult Anfield.
- Optional rear ports available.
- Standard drive shaft is **5/8" straight shaft with 5/32" key**.
- Optional shafts include an SAE 9 tooth spline and a 3/4" straight shaft with a 3/16" key.



TECHNICAL DATA

- Filtration: 25 micron or better
- Oil Viscosity: 6 to 200 cSt
- Inlet Pressure: 12 to 32 psi absolute
- Temperature: Oil: -25°C to 80°C / -12°F to 175°F
Ambient: -22°C to 55°C / -8°F to 130°F
- Port Sizes: Inlet: SAE-12 (1-1/16"-12 UNF)
Outlet: SAE-10 (7/8"-14 UNF)

Model	GPM @ 1800 rpm	Displacement		Pressure		Speed RPM		Weight	
		cm3/rev	cu.in/rev	PSI	BAR	Min.	Max.	Lbs.	Kg
AP-20-6.0	2.80	6.0	0.36	3650	250	500	3600	8.35	3.80
AP-20-7.0	3.35	7.0	0.43	3650	250	500	3600	8.28	3.75
AP-20-8.0	3.74	8.0	0.48	3650	250	500	3600	8.61	3.90
AP-20-10	4.75	10	0.61	3650	250	500	3600	8.72	3.95
AP-20-11	5.22	11	0.67	3650	250	500	3600	8.83	4.00
AP-20-12	5.69	12	0.73	3650	250	500	3600	8.91	4.04
AP-20-14	6.62	14	0.85	3650	250	500	3600	9.00	4.08
AP-20-16	7.56	16	0.97	2900	200	500	3000	9.27	4.20
AP-20-20	9.51	20	1.22	2900	200	500	3000	9.73	4.41
AP-20-22	10.44	22	1.34	2900	200	500	3000	9.90	4.49
AP-20-25	11.84	25	1.52	2900	200	500	3000	10.19	4.62

- Flow rate in gpm - Displacement (cu.in/rev) X speed (rpm)/231
- Volumetric efficiency % >93

Hydraulic Gear Pump AP-20



INSTALLATION DATA

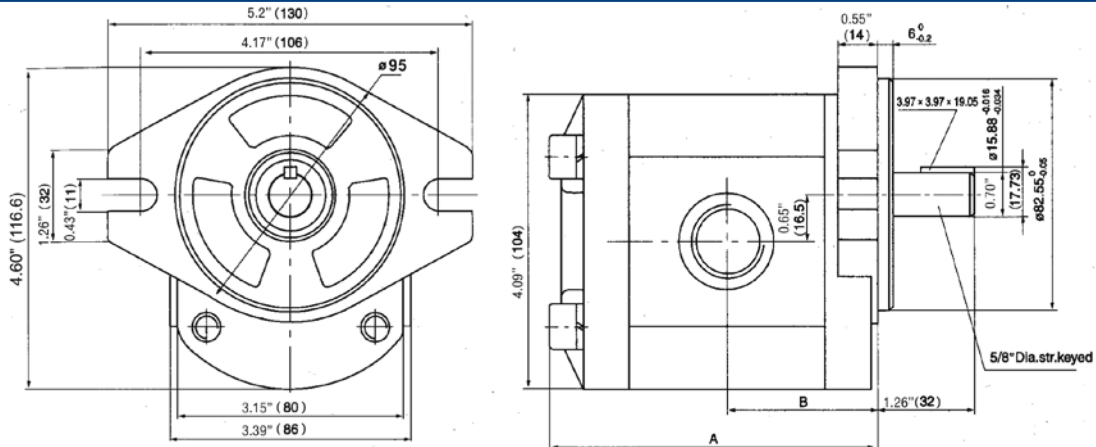

Model	A		B	
	mm	inch	mm	inch
AP-20-6.0	98	3.87	45	1.77
AP-20-7.0	99.5	3.91	45.75	1.80
AP-20-8.0	102	4.02	47	1.85
AP-20-10	104	4.12	48	1.89
AP-20-11	106	4.17	49	1.93
AP-20-12	108	4.25	50	1.97
AP-20-14	110	4.35	51	2.0
AP-20-16	114	4.50	53	2.09
AP-20-20	120	4.75	56	2.20
AP-20-22	123	4.92	57.5	2.26
AP-20-25	128	5.05	60	2.36

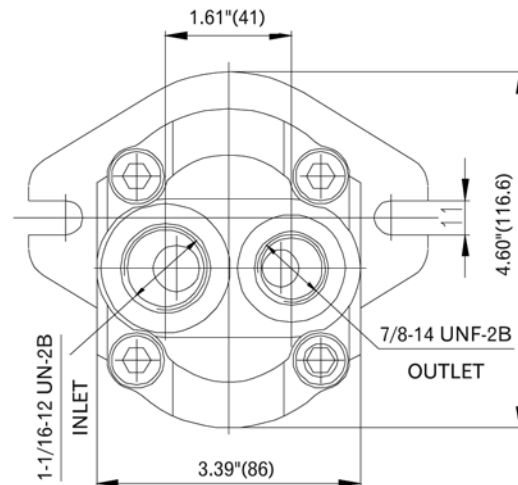

* Special order
For P1 diagram see page 11

ORDERING INFORMATION

